

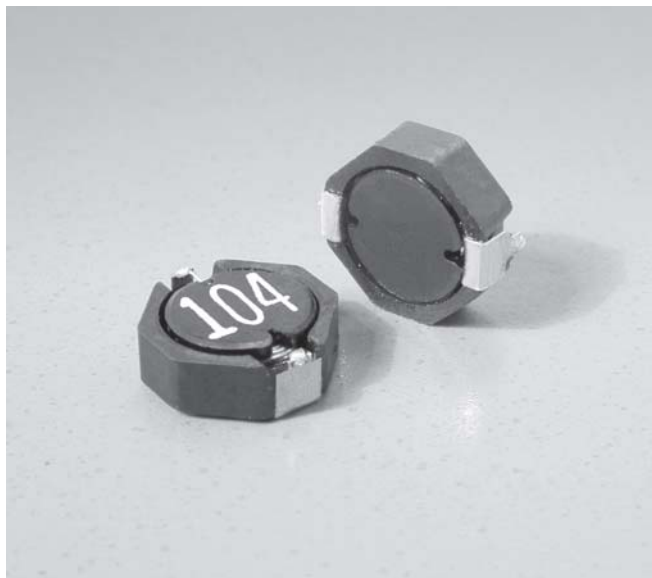

# SMT Power Inductors – MOS6020



- 6.0 × 7.1 mm footprint; 2.4 mm high shielded inductors
- Custom versions up to 4.7 mH are available.

**Designer's Kit C359** contains 3 of each value

**Core material** Ferrite

**Core and winding loss** See [www.coilcraft.com/coreloss](http://www.coilcraft.com/coreloss)

**Terminations** RoHS compliant matte tin over nickel over phos bronze. Other terminations available at additional cost.

**Weight** 0.21 g

**Ambient temperature** –40°C to +85°C with I<sub>rms</sub> current, +85°C to +125°C with derated current

**Storage temperature** Component: –40°C to +125°C.

Packaging: –40°C to +80°C

**Resistance to soldering heat** Max three 40 second reflows at +260°C, parts cooled to room temperature between cycles

**Moisture Sensitivity Level (MSL)** 1 (unlimited floor life at <30°C / 85% relative humidity)

**Failures in Time (FIT) / Mean Time Between Failures (MTBF)**

38 per billion hours / 26,315,789 hours, calculated per Telcordia SR-332

**Packaging** 500 per 7" reel; 2000 per 13" reel; Plastic tape: 16 mm wide, 0.3 mm thick, 12 mm pocket spacing, 2.5 mm pocket depth

**PCB washing** Only pure water or alcohol recommended

Part number <sup>1</sup>	Inductance <sup>2</sup> ±20% (µH)	DCR max (Ohms)	SRF typ <sup>3</sup> (MHz)	Isat (A) <sup>4</sup>			Irms (A) <sup>5</sup>	
				10% drop	20% drop	30% drop	20°C rise	40°C rise
MOS6020-222ML_	2.2	0.035	110	2.86	3.26	3.56	3.0	4.1
MOS6020-332ML_	3.3	0.046	85	1.90	2.28	2.46	2.6	3.6
MOS6020-472ML_	4.7	0.050	60	1.46	1.82	1.94	2.3	3.1
MOS6020-682ML_	6.8	0.078	55	1.32	1.56	1.72	1.9	2.7
MOS6020-822ML_	8.2	0.085	45	0.94	1.18	1.30	1.7	2.3
MOS6020-103ML_	10	0.092	36	0.79	0.95	1.06	1.6	2.2
MOS6020-153ML_	15	0.130	30	0.83	0.95	1.03	1.3	1.8
MOS6020-223ML_	22	0.182	22	0.79	0.92	0.97	1.0	1.4
MOS6020-333ML_	33	0.290	20	0.57	0.67	0.74	0.80	1.1
MOS6020-473ML_	47	0.420	16	0.45	0.56	0.62	0.50	0.7
MOS6020-683ML_	68	0.520	15	0.37	0.45	0.51	0.45	0.63
MOS6020-104ML_	100	0.800	13	0.35	0.40	0.44	0.40	0.56
MOS6020-154ML_	150	1.28	10	0.26	0.30	0.33	0.35	0.49
MOS6020-224ML_	220	2.00	8	0.22	0.26	0.28	0.30	0.42
MOS6020-334ML_	330	2.84	7	0.18	0.22	0.24	0.25	0.35
MOS6020-474ML_	470	4.40	5	0.15	0.17	0.19	0.22	0.29

1. When ordering, please specify **termination** and **packaging** codes:

**MOS6020-104ML C**

**Termination:** L = RoHS compliant matte tin over nickel over phos bronze. Special order: T = RoHS tin-silver-copper (95.5/4/0.5) or S = non-RoHS tin-lead (63/37).

**Packaging:** C = 7" machine-ready reel. EIA-481 embossed plastic tape (500 parts per full reel).

B = Less than full reel. In tape, but not machine ready. To have a leader and trailer added (\$25 charge), use code letter C instead.

D = 13" machine-ready reel. EIA-481 embossed plastic tape (2000 parts per full reel).

2. Inductance tested at 100 kHz, 0.1 Vrms, 0 Adc using an Agilent/HP 4263B LCR meter or equivalent.

3. SRF measured using Agilent/HP 8753D network analyzer.

4. DC current at which the inductance drops the specified amount from its value without current.

5. Current that causes the specified temperature rise from 25°C ambient.

6. Electrical specifications at 25°C.

Refer to Doc 362 "Soldering Surface Mount Components" before soldering.

**Coilcraft**<sup>®</sup>

Specifications subject to change without notice.  
Please check our website for latest information.

Document 287-1 Revised 10/06/08

1102 Silver Lake Road Cary, Illinois 60013 Phone 847/639-6400 Fax 847/639-1469

E-mail [info@coilcraft.com](mailto:info@coilcraft.com) Web <http://www.coilcraft.com>



# SMT Power Inductors - MOS6020

## Typical L vs Frequency

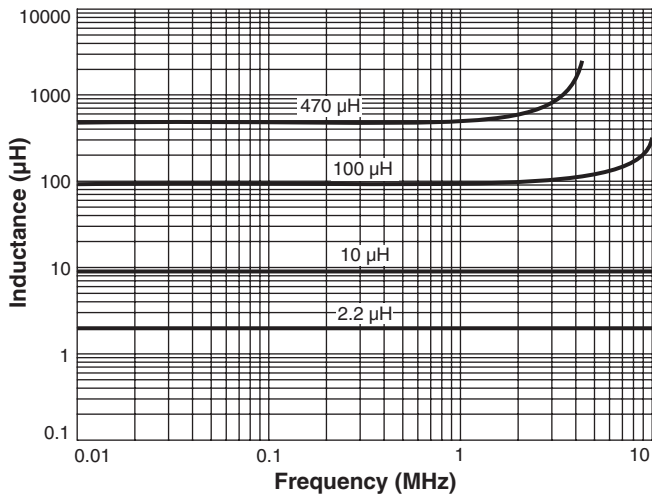

## Typical L vs Current

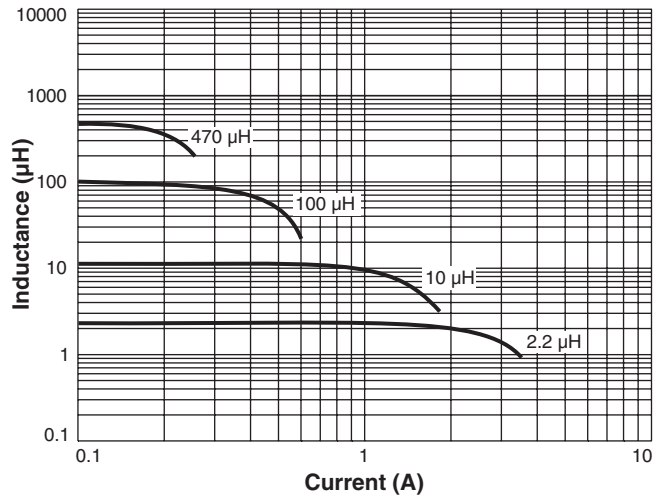

## Irms Derating

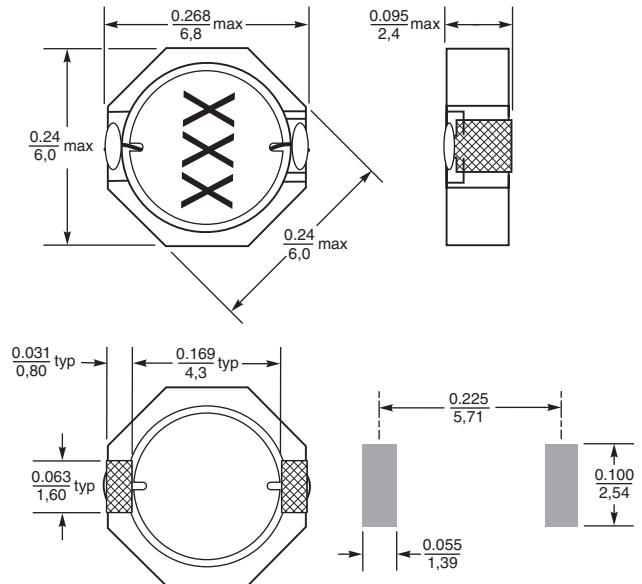
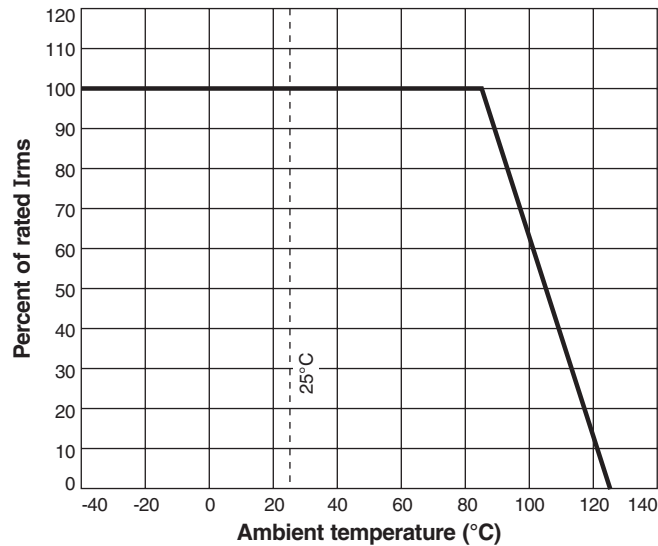

**Recommended Land Pattern**

Dimensions are in  $\frac{\text{inches}}{\text{mm}}$



Specifications subject to change without notice. Please check our website for latest information.

Document 287-2 Revised 10/06/08

1102 Silver Lake Road Cary, Illinois 60013 Phone 847/639-6400 Fax 847/639-1469

E-mail [info@coilcraft.com](mailto:info@coilcraft.com) Web <http://www.coilcraft.com>